

## STAINLESS STEEL THREE PHASE MOTOR

### Model SS54CF

Voltage <u>575</u>	Hz <u>60</u>	Shaft Material <u>304 Stainless Steel</u>	Design <u>B</u>
Phase <u>3</u>	Encl <u>TEFC</u>	Ambient <u>40°C</u>	Duty Cycle <u>S1</u>
IP <u>69</u>	KVA <u>J</u>	Altitude <u>3300FT</u>	Rotation <u>CW/CCW</u>
	Ins. Cl. <u>F</u>	Mounting <u>F1</u>	Inverter Duty <u>10:1 CT 20:1 VT</u>

HP	RPM	S.F.	Frame	Amps 575 V		Locked Rotor Amps	No Load Current	Lead / Connect	Moment of Inertia	Temp. Rise, °C
5	1760	1.15	184TC	5.37		36.8	2.72	6 / Y	—	80
Bearing		Efficiency, %		Power Factor		Rated Torque, lb.ft.	Locked Rotor Torque, %	Breakdown Torque, %	Max Time Locked Rotor	Weight, lbs
DE	ODE	FL	3/4L	FL	3/4L					
6306ZZ	6306ZZ	89.5	89.6	0.78	—	15	230	290	16 SEC	100

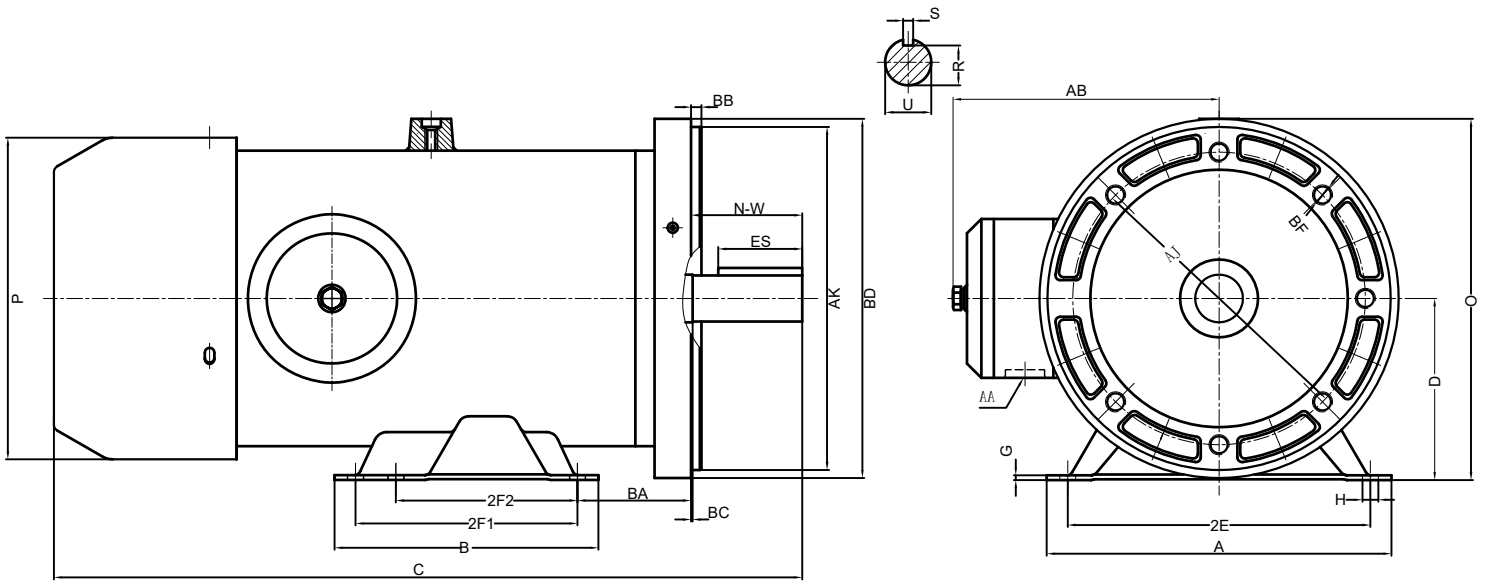

Dimensions in inches

A	B	C	D	G	H	O	P	AB	
8.54	6.54	17.72	4.5	0.12	0.41	8.95	8	6.34	
R	S	AK	BD	BB	BC	AJ	AA	BF	
0.986	0.25	8.5	8.9	0.25	0.12	7.25	1	1/2-13	
SHAFT EXTENSION			MOUNTING						
N-W	U	ES	2E	2F1	2F2	BA			
2.75	1.125	1.78	7.5	5.5	4.5	3.5			

