

## STAINLESS STEEL THREE PHASE MOTOR

### Model SS24CFH

|                    |                   |   |                                      |
|--------------------|-------------------|---|--------------------------------------|
| Voltage <u>575</u> | Hz <u>60</u>      | Shaft Material <u>304 Stainless Steel</u> | Design <u>B</u>                      |
| Phase <u>3</u>     | Encl <u>TEFC</u>  | Ambient <u>40°C</u>                       | Duty Cycle <u>S1</u>                 |
| IP <u>69</u>       | KVA <u>L</u>      | Altitude <u>3300FT</u>                    | Rotation <u>CW/CCW</u>               |
|                    | Ins. Cl. <u>F</u> | Mounting <u>F1</u>                        | Inverter Duty <u>10:1 CT 20:1 VT</u> |

| HP      | RPM    | S.F.          | Frame | Amps 575 V   |      | Locked Rotor Amps    | No Load Current        | Lead / Connect      | Moment of Inertia     | Temp. Rise, °C |
|---------|--------|---------------|-------|--------------|------|----------------------|------------------------|---------------------|-----------------------|----------------|
| 2       | 1750   | 1.15          | 56HC  | 2.28         |      | 20                   | 1.45                   | 6 / Y               | —                     | 80             |
| Bearing |        | Efficiency, % |       | Power Factor |      | Rated Torque, lb.ft. | Locked Rotor Torque, % | Breakdown Torque, % | Max Time Locked Rotor | Weight, lbs    |
| DE      | ODE    | FL            | 3/4L  | FL           | 3/4L |                      |                        |                     |                       |                |
| 6205ZZ  | 6205ZZ | 86.5          | 86.4  | 0.78         | —    | 6                    | 290                    | 320                 | 20 SEC                | 47             |

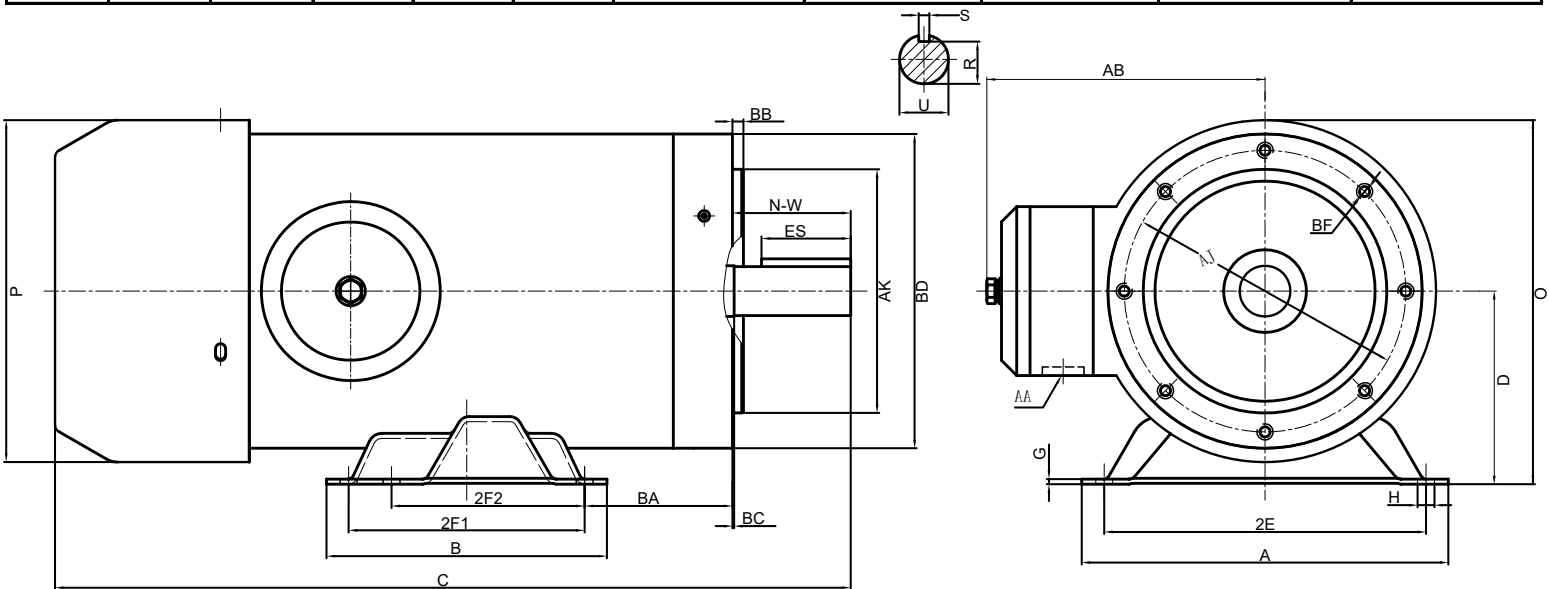

Dimensions in inches

| A               | B     | C     | D        | G    | H    | O    | P    | AB     |
|-----------------|-------|-------|----------|------|------|------|------|--------|
| 6.54            | 5.98  | 14.12 | 3.5      | 0.12 | 0.34 | 6.73 | 6.85 | 5.93   |
| R               | S     | AK    | BD       | BB   | BC   | AJ   | AA   | BF     |
| 0.517           | 0.188 | 4.5   | 6.46     | 0.16 | 0.12 | 5.88 | 3/4  | 3/8-16 |
| SHAFT EXTENSION |       |       | MOUNTING |      |      |      |      |        |
| N-W             | U     | ES    | 2E       | 2F1  | 2F2  | BA   |      |        |
| 1.88            | 0.625 | 1.41  | 5.5      | 5    | 4    | 2.75 |      |        |

