

# AG-I MotorTec Inc.



## STAINLESS STEEL THREE PHASE MOTOR

### SS204CF

Voltage	<u>575</u>	Hz	<u>60</u>	Shaft Material	<u>304 Stainless Steel</u>	Design	<u>B</u>
Phase	<u>3</u>	Encl	<u>TEFC</u>	Ambient	<u>40°C</u>	Duty Cycle	<u>S1</u>
IP	<u>69K</u>	KVA	<u>G</u>	Altitude	<u>3300FT</u>	Rotation	<u>CW/CCW</u>
		Ins. Cl.	<u>F</u>	Mounting	<u>F1</u>	Inverter Duty	<u>10:1 CT 20:1 VT</u>

HP	RPM	S.F.	Frame	Amps 575V		Locked Rotor Amps	No Load Current	Lead / Connect	Full Load Temp. Rise	Temp. Rise, °C
20	1780	1.15	256TC	19.2		116	6.86	6 / Δ	—	80
Bearing		Efficiency, %		Power Factor		Rated Torque, lb.ft.	Locked Rotor Torque, %	Breakdown Torque, %	Max Time Locked Rotor	Weight, lbs
DE	ODE	FL	3/4L	FL	3/4L	59.4	200	280	18 SEC	
6309ZZ	6308ZZ	93	93.1	0.84	—					

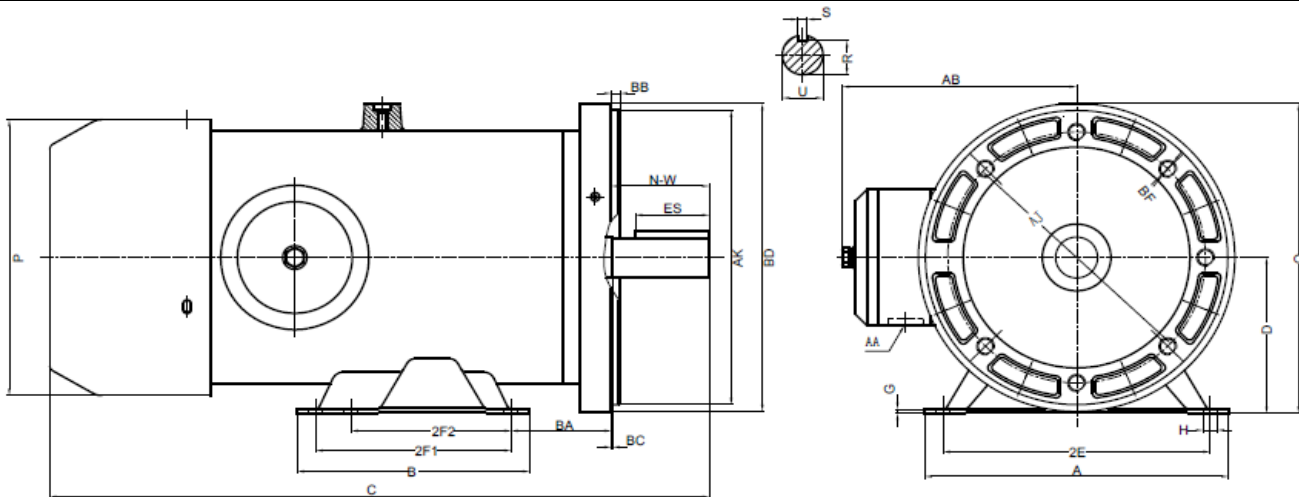

Dimensions in inches

A	B	C	D	G	H	O	P	AB
11.18	11.18	24.69	6.25	0.20	0.53	13.30	13.30	9.60
R	S	AK	BD	BB	BC	AJ	AA	BF
1.416	0.375	8.50	11.80	0.25	0.25	7.25	1 1/2	1/2-13
SHAFT EXTENSION			MOUNTING					
N-W	U	ES	2E	2F1	2F2	BA		
4.00	1.625	2.91	10.00	10.00	8.25	4.75		

