

## STAINLESS STEEL THREE PHASE MOTOR

### Model SS144CF

Voltage	<u>575</u>	Hz	<u>60</u>	Shaft Material	<u>304 Stainless Steel</u>	Design	<u>B</u>
Phase	<u>3</u>	Encl	<u>TEFC</u>	Ambient	<u>40°C</u>	Duty Cycle	<u>S1</u>
IP	<u>69K</u>	KVA	<u>K</u>	Altitude	<u>3300FT</u>	Rotation	<u>CW/CCW</u>
		Ins. Cl.	<u>F</u>	Mounting	<u>F1</u>	Inverter Duty	<u>10:1 CT 20:1 VT</u>

HP	RPM	S.F.	Frame	Amps 575 V		Locked Rotor Amps	No Load Current	Lead / Connect	Moment of Inertia	Temp. Rise, °C
0.25	1780	1.15	56C	0.39		3.59	0.32	6 / Y	—	80
Bearing		Efficiency, %		Power Factor		Rated Torque, lb.ft.	Locked Rotor Torque, %	Breakdown Torque, %	Max Time Locked Rotor	Weight, lbs
DE	ODE	FL	3/4L	FL	3/4L					
6203ZZ	6203ZZ	65	61	0.52	0.46	0.745	305	412	16 Sec	29

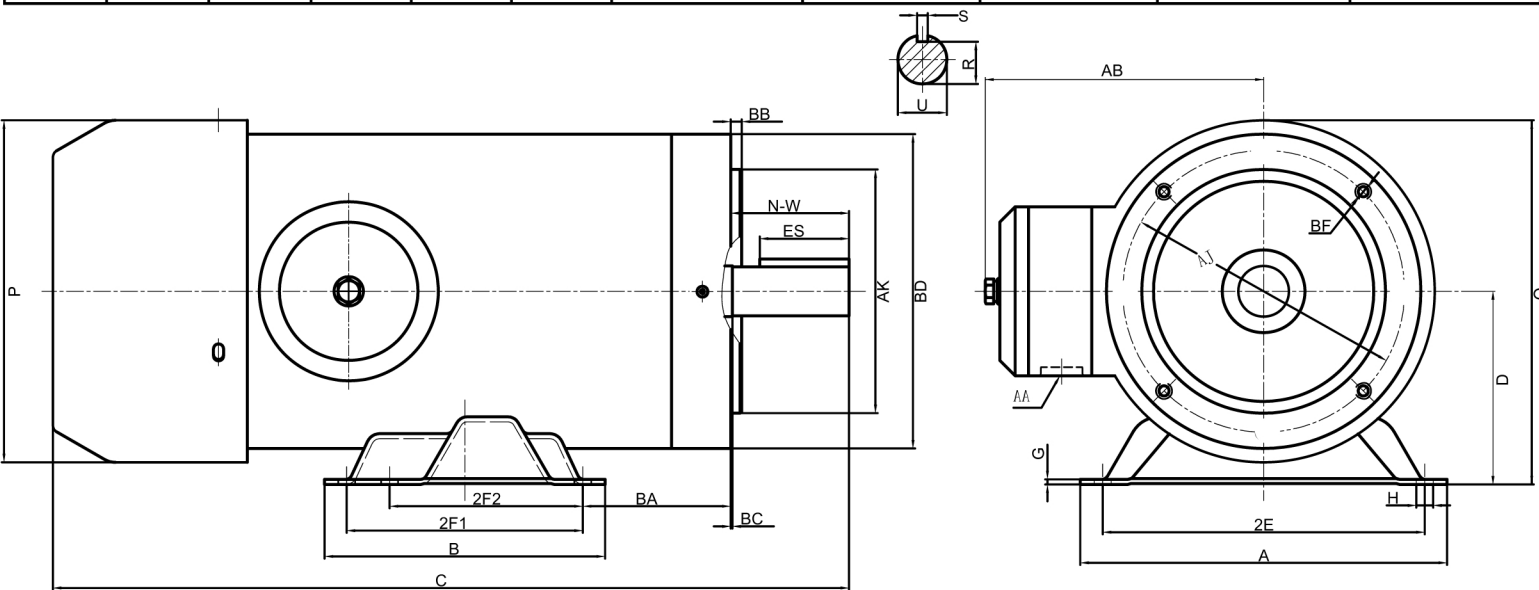

Dimensions in inches

A	B	C	D	G	H	O	P	AB
6.5	3.94	10.76	3.5	0.12	0.34	6.73	6.46	5.93
R	S	AK	BD	BB	BC	AJ	AA	BF
0.517	0.188	4.5	6.46	0.16	0.12	5.875	3/4	3/8-16
SHAFT EXTENSION			MOUNTING					
N-W	U	ES	2E	2F1	2F2	BA		
1.88	0.625	1.41	5.5	—	3	2.75		

