

D = Shaft height measured at the centerline
 E = Distance from the centerline to the side mounting holes
 F = Distance between the mounting holes
 BA = Distance from the center of the nearest mounting hole to the beginning of the usable shaft
 U = Shaft diameter
 N-W = shaft length

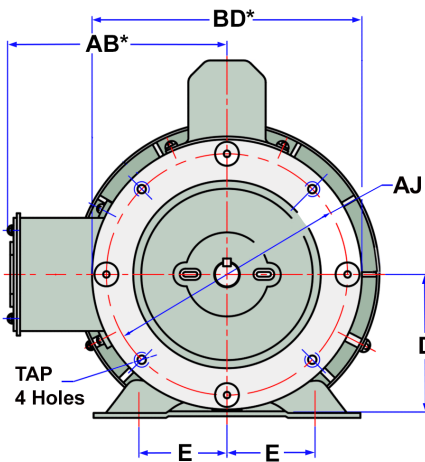
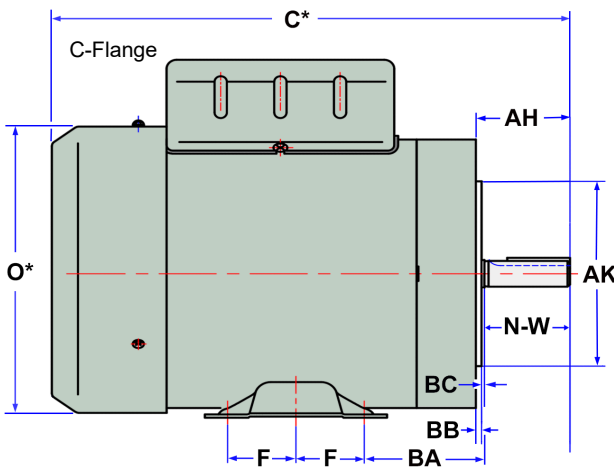

For AG-I specific model dimensions, visit our website:
ag-industrie.com

email,
info@agimotortec.com

or directly contact your
AG-I representative.
 (see back page)

* Dimensions marked with * are not specified by NEMA, and vary by manufacturer.

FRAME	D	E	F	BA	U	NW	AH	AJ	AK	BB	KEY	TAP
42	2-5/8	1-3/4	27/32	2-1/16	3/8	1-1/8	1-5/16	3-3/4	3	1/8	3/64 Flat	1/4-20
48	3	2-1/8	1-3/8	2-1/2	1/2	1-1/2	1-11/16	3-3/4	3	1/8	3/64 Flat	1/4-20
56 56H	3-1/2	2-7/16	1-1/2 2.5	2-3/4	5/8	1-7/8	2-1/16	5-7/8	4-1/2	1/8	3/16 square	3/8-16
143T 145T	3-1/2	2-3/4	2 2.5	2-1/4	7/8	2-1/4	2-1/8	5-7/8	4-1/2	1/8	3/16 square	3/8-16
182T 184T	4-1/2	3-3/4	2-1/4 2-3/4	2-3/4	1-1/8 1-1/8	2-3/4 2-3/4	2-5/8 2-5/8	7-1/4	8-1/2	1/4 1/4	5/16 square	1/2-13 1/2-13
213T 215T	5-1/4	4-1/4	2-3/4 3-1/2	3-1/2	1-3/8 1-3/8	3-3/8 3-3/8	3-1/8 3-1/8	7-1/4	8-1/2	1/4	5/16 square	1/2-13
254T 256T	6-1/4	5	4-1/8 5	4-1/4	1-5/8 1-5/8	4.0 4,0	3-3/4 3-3/4	7-1/4	8-1/2	1/4	3/8 square	1/2-13
284T 286T	7	5-1/2	4-3/4 5-1/2	4-3/4	1-7/8 1-7/8	4-5/8 4-5/8	4-3/8 4-3/8	9.0	10-1/2	1/4	1/2 square	1/2-13